



# Modeling and Analysis of Asymmetrical Faults for Relay Settings in Electric Power Protection System Learning

Abd. Hakim Butar-Butar<sup>1</sup>, Agus Junaidi<sup>2</sup>, Marwan Afandi<sup>3</sup>, Sempurna Perangin-Angin<sup>4</sup>, Rahmaniar<sup>5</sup>

<sup>1,2,3,4</sup>Universitas Negeri Medan, Indonesia

<sup>5</sup>Universitas Pembangunan Pancabudi, Indonesia

Email: [abdulhakimbutar@unimed.ac.id](mailto:abdulhakimbutar@unimed.ac.id), [agusjunaidi@unimed.ac.id](mailto:agusjunaidi@unimed.ac.id), [marwanafandi@unimed.ac.id](mailto:marwanafandi@unimed.ac.id), [sempurnaperangin@gmail.com](mailto:sempurnaperangin@gmail.com), [rahmaniar@dosen.pancabudi.ac.id](mailto:rahmaniar@dosen.pancabudi.ac.id)

## **Abstract:**

*This study examines the analysis of Asymmetrical fault, namely single-phase ground faults for e-jobsheet products based on Information and Communication Technology (ICT) or utilizing computer programs for study. A study of short-circuit faults in the electric power system, is used to solve problems in the field of reliability and protection. the electric power system, namely the handling of single-phase short-circuit faults to ground which, if not neutralized, cause equipment damage to the electric power system. Parameters from modeling and analysis of asymmetrical faults are used for setting the Ground Fault Relay or often known as the Ground Fault Relay (GFR). The research study begins with modeling the interconnection system in the form of a reactance diagram, then modeling it with the bus impedance matrix equation, to determine the magnitude of the short circuit impedance value on the diagonal matrix. Then calculate the fault current of a single-phase short circuit to ground. From these results it is determined to determine the amount of the relay setting. The results showed that the asymmetrical fault current was 3.0 Pu with a setting time value of 2,45 seconds. The results of the study are used for learning relay settings. The simulation program was validated by experts, with a very good category with an Aikensv index of 0.872.*

## **Keywords:**

*asymmetrical fault; modeling and analysis; protection relay, teaching and learning*

## I. Introduction

Short circuit fault is a system state in which transient state conditions that must be overcome by the safety equipment. The occurrence of a short circuit results in the emergence of a current surge with a magnetude higher than normal and the voltage in that place becomes very low which can cause result in damage to insulation, mechanical damage to conductors, electrical sparks and worstcase system failure. In the neutral point grounding system, if there is a phase-to-ground short circuit, the fault current that will arise will be large and the electric arc will no longer be extinguished by itself. If the disturbance is not immediately neutralized, the continuity of electricity distribution will stop, which means it can cause considerable losses. The increase in the value of the ground fault current is caused by the influence of the capacitance and the transmission line. If there is a single-phase short circuit to ground, a large ground fault current will arise due to linedischarging from the transmission line. This disturbance condition can be analyzed by utilizing computer technology in the form of simulation, as an analytical tool (Junaidi, A, 2017).

Skills in using information technology and computers are the type of expertise that will be needed by the business world and industry in the industrial era 4.0. The ability of university

graduates to collaborate, adapt to technology and computer programming as well as critical thinking skills are competencies that must be prepared for global competitiveness. In the aspect of using information technology in learning, computer simulations can be a means of developing the quality of teaching lecturers in the laboratory room, for the field of electric power system analysis. The use of simulation can provide a stimulus and passion for learning that has an impact on changes in student learning behavior in achieving maximum learning goals (Rahmaniar, 2019). A study on the use of computerbased learning simulation (SCBL) technology for the field of electrical power interconnection systems. The simulation is carried out starting by modeling the system in the form of a bus impedance matrix, for short circuit analysis studies. The plant that is used as the case is a multi-machine interconnection system. Furthermore, calculations are carried out using matlab simulation, the simulation results show that, practically, it can determine the magnitude of the short-circuit fault current. The model that has been built is implemented in the study of electric power system analysis in the electrical engineering study program, Faculty of Engineering Unpab (Maharani, 2017).

## II. Review of Literature

### Power System Protection

#### a. Main Elements of Protection System

The protection system is the process of protecting the system due to a disturbance, using a relay device that works automatically to regulate the pickup (open) the circuit in the event the system is in trouble, this condition is done to overcome equipment damage, because in the system that is experiencing interference, the voltage and current rating working in abnormal conditions. The protection consists of 4 main devices which are the system, namely (1) Relay, as a sensing device to detect disturbances which then gives a trip command to the Circuit Breaker (CB); (2) Current transformer and/or voltage transformer as a device that transfers primary electricity quantities from the secured system to relays (secondary electrical quantities); (3).Power breaker (CB) to separate the disturbed part of the system; (4) The source of direct current (Battery) along with the battery charger for the source of the relay, or referred to as tripping auxiliary equipment (Alstom, 2011) . The four main components are assembled in a wiring system, as shown in figure 1.

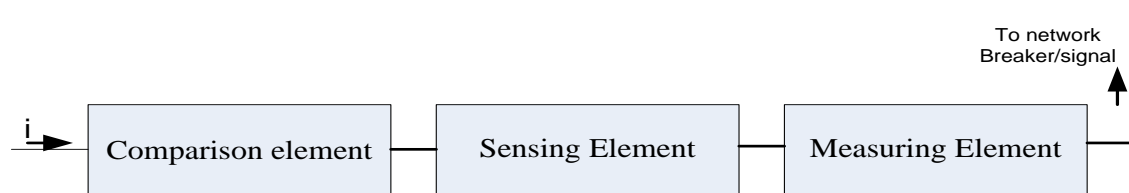
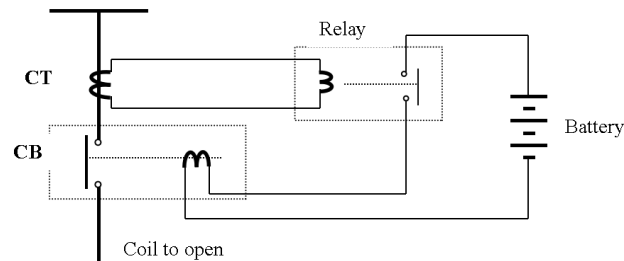

Figure 1. Main Block Diagram of Protection Relay

Figure 1 shows the 3 main blocks of protection elements (ABB, 2010), each element has the following functions: (a) Sensing element, this element functions to sense electrical quantities, such as current, voltage, frequency, and so on depending on the relay used. In this section, the condition of the incoming quantity will be felt, whether the protected condition is disturbed or in normal condition, then the quantity is sent to the comparison element.(b). (b). Comparison element, this element functions to receive the amount after the amount is first received by the element by the sensing element to compare the electrical quantity under normal conditions with the amount of the relay working current. (c) Measuring/determining element, this element serves to make a quick change in the size of the measurement and will immediately give a signal to open the CB or give a signal.

**b. Protection Relay Working Principle**

The protection relay works when the system is faulty. Various types of relays are installed to handle various types of disturbances, both technical (internal) and natural (external) aspects such as lightning and natural disasters. In general, the circuit in Figure 2 is used to describe the working principle of the protection relay in dealing with fault problems.



*Figure 2. Protection Relay Circuit*

Figure 2, shows a simple circuit to explain the working principle of a protection relay. Under normal conditions the current passing through the Current Transformer (CT) does not respond to the relay, but when a phase-to-ground fault occurs, the CT will signal to the relay that a fault current has occurred. The relay is set to detect a disturbance signal, so that when a fault current occurs, the relay system will close the contacts and the DC voltage source (Battery) will provide power to the Circuit Breaker coil, which was previously in Normally Close (NC) condition, it will turn open. This means that the disturbance will be neutralized by the CB circuit by disconnecting it. In this situation, the most important thing in the protection relay is the setting of the relay to be really sensitive to receive fault signals.

**c. Single-Phase Ground Short Circuit Fault Theory**

Zero, positive and negative equivalent circuits are used in power systems. In the main simplification is basically not affect the accuracy of the results obtained, they consist of: (a) The shunt element in the transformer model is calculated, the magnetizing current and core losses are negligible; (b) The shunt capacitance in the network model is neglected; (c) The steady state circuit analysis technique is used; (d) set the internal system voltage source  $1\angle 0^\circ$ .

Figure 3, shows a block diagram for a single-phase short-circuit to ground fault. Fault Single phase to ground short circuit occurs in phase a, with a ground fault impedance value of  $Z_f$ .

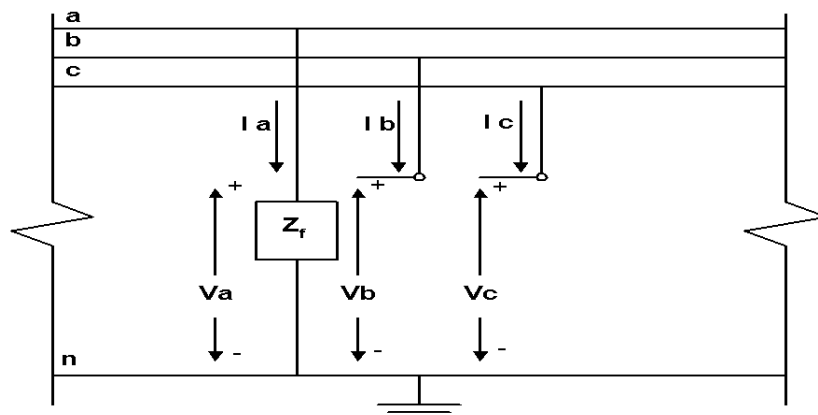

*Figure 3. Diagram of Single-Phase Ground Fault Conditions*

The basic considerations in solving the problem of single-phase short-circuit to ground are generally depicted in Figure 4. +, - and 0 sequence circuits for single-phase to ground faults are connected in series (Metz, 2005).

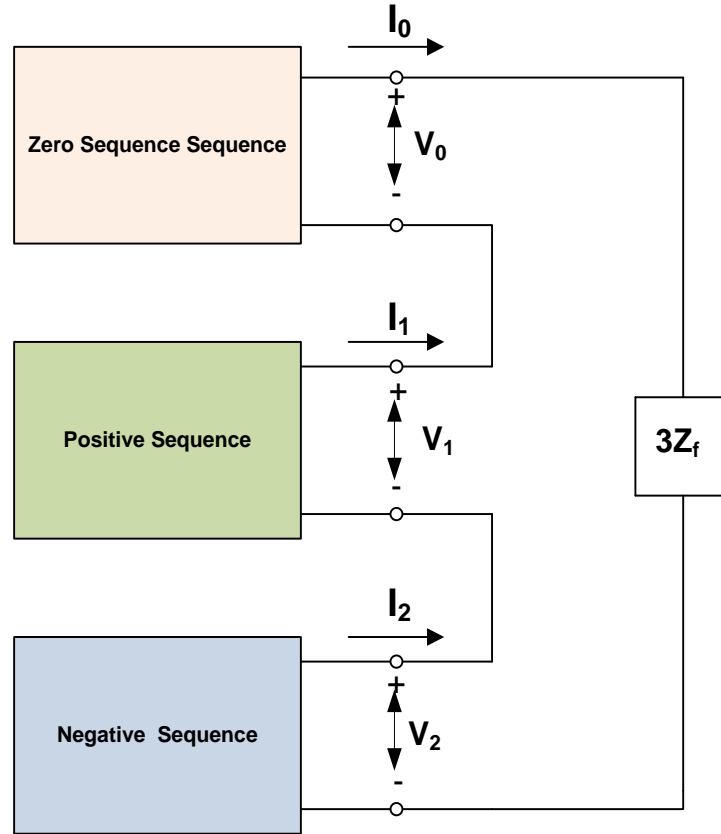

**Figure 4.** Replacement Circuit for Single Phase Ground Fault Short Circuit

During the fault, the single-phase to-ground short-circuit fault, the state of the system written in the equation is:

$$I_b = I_c = 0 \tag{1}$$

$$V_a = I_a Z_f \tag{2}$$

From the equation

$$I_0 + a^2 I_1 + a I_2 = I_0 + a I_1 + a^2 I_2 \tag{3}$$

Manipulating equation 3, we get:

$$(a^2 - a)I_1 = (a^2 - a) I_2 \tag{4}$$

Or

$$I_1 = I_2 \tag{5}$$

$$I_b = I_0 + a^2 I_1 + a I_2 = 0 \tag{6}$$

$$I_0 + (a^2 + a) I_1 = 0 \tag{7}$$

$$I_0 = - (a^2 + a) I_1 \tag{8}$$

$$I_0 = I_1 \tag{9}$$

So that equation 10 is obtained, as follows:

$$\begin{aligned}
V_a &= Z_f I_a \\
V_0 + V_1 + V_2 &= Z_f (I_0 + I_1 + I_2) \\
V_0 + V_1 + V_2 &= 3Z_f I_1
\end{aligned} \tag{10}$$

### III. Research Methods

#### a. Single-phase Ground Fault Model

Suppose a single-phase short-circuit fault current to ground occurs at bus-i. General equation for single-phase short-circuit fault current to ground on a faulty Bus  $(i)$  (Hadi, 1999):

$$\bar{I}_i^{-1} = \frac{\bar{E}}{\bar{Z}_f + z_{ii}^{-1} + z_{ii}^{-2} + z_{ii}^{-0}} \tag{12}$$

The voltage on the j Bus, written by the equation:

$$\begin{aligned}
V_j^{-1} &= \bar{E} - z_{ji}^{-1} \bar{I}_i^{-1} \\
V_j^{-0} &= -z_{ji}^{-0} \bar{I}_i^{-0} \\
V_j^{-2} &= -z_{ji}^{-2} \bar{I}_i^{-2}
\end{aligned} \tag{13}$$

Fault current single phase to ground on bus-i

$$I_i^0(F) = I_i^1(F) = I_i^2(F) = \frac{V_f}{z_{ii}^{-0} + z_{ii}^{-1} + z_{ii}^{-2} + 3Z_f} \tag{14}$$

Then the fault current of each phase on bus-i

$$I_i^{abc}(F) = \begin{bmatrix} 1 & 1 & 1 \\ 1 & a^2 & a \\ 1 & a & a^2 \end{bmatrix} \begin{bmatrix} I_i^0(F) \\ I_i^1(F) \\ I_i^2(F) \end{bmatrix} \tag{15}$$

The voltage on the symmetrical components for positive sequence, negative sequence and zero sequence is expressed by the equation:

$$V_1^{012}(F) = \begin{bmatrix} 0 - Z_{j-i}^{-0} I_i^0 \\ V_1^1(0) - Z_{j-i}^{-1} I_i^1 \\ 0 - Z_{j-i}^{-2} I_i^2 \end{bmatrix} \tag{16}$$

$$V_2^{012}(F) = \begin{bmatrix} 0 - Z_{j-i}^0 I_i^0 \\ V_2^1(0) - Z_{j-i}^1 I_i^1 \\ 0 - Z_{j-i}^2 I_i^2 \end{bmatrix} \quad (17)$$

$$V_3^{012}(F) = \begin{bmatrix} 0 - Z_{ji}^0 I_i^0 \\ V_2^1(0) - Z_{ji}^1 I_i^1 \\ 0 - Z_{ji}^2 I_i^2 \end{bmatrix} \quad (18)$$

### b. Research Stages

The research was carried out in stages as shown in figure 5:

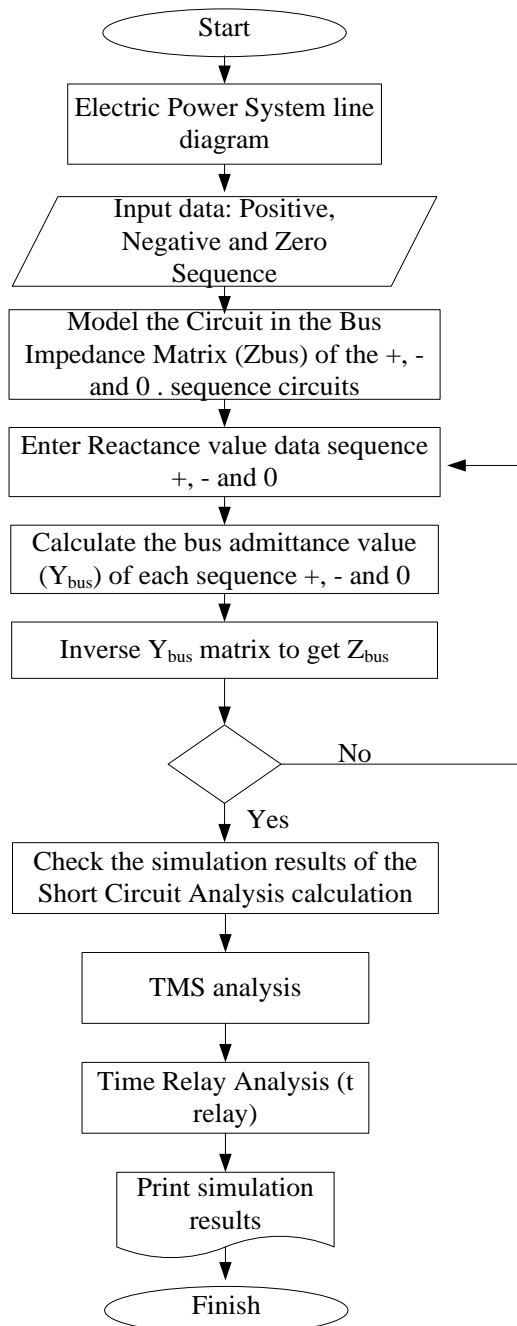

Figure 5. Research Stages

Figure 5, shows the stages of research in determining the GFR setting in the electric power system. The research begins with the identification of data from scientific sources, then draws an inline diagram based on system data. From the inline diagram, the bus impedance matrix ( $Z_{bus}$ ) for the +, - and 0 sequences will be arranged. From this, the bus impedance matrix value will be obtained, which represents the short-circuit impedance value. From the Y bus matrix, the Zbus matrix will then be obtained and the magnitude of the single-phase fault current to ground will be calculated (Nasser, 2008). The value of the single-phase fault current to ground is used as a parameter to determine the TMS and time setting of GFR

### c. Calculation of Protection Relay Settings

The electric power protection system, designed to handle disturbances properly, must have requirements in carrying out its function as a safety. These requirements must be met by each component of the protective equipment. By working optimally, the protection system will run well in accordance with its function to protect equipment from damage due to interference. Some of the requirements for the protection system, namely (1) Sensitivity. In principle, the protection equipment must be able to detect interference with minimum stimulation from the source of interference. An example is a phase short circuit with ground, where the conductor wire breaks and hits a tree or house. Trees and houses have considerable resistance, so the single-phase-ground fault current sensed by the relay is small; (2) Reliability The protection system must be reliable as long as possible, so that when a disturbance or abnormal condition occurs, the protection system can work at any time to protect distribution equipment. The reliability of the protection system from the initial setting must be maintained for as long as possible; (3) Selectivity (Selectivity) Protection equipment must selectively work on the system that is affected by interference, so that the system that is not affected by interference is not affected by the protection system. In addition, protection can also distinguish whether the disturbance is in the main safety area or backup protection, and the protection must work instantaneously or with a time delay; (4) Speed To minimize/minimize losses due to interference, the disturbed parts must be separated as quickly as possible, so that the protective equipment must also work quickly to free the disturbed parts. Delay in work of protective equipment can disrupt the system or damage the equipment by thermal stress.[sxsxs]

To determine selectivity and reliability, careful analysis is needed in determining relay settings. Calculation of overcurrent relay settings the first thing to know is that the parameters set on the safety relay are current and time. To determine the amount of current and working time of the relay, data from the equipment secured by the relay is required to be calculated using the following:

$$I_n = \frac{KVA}{\sqrt{3} \times KV} \tag{19}$$

$I_n = I_{base} = \text{arus nominal}$

$I_p = 0,1 \times I_f \text{ single phase ground fault current}$

$I_s = I_p \times \text{CT ratio}$

$I_s = \text{secondary setting current}$

$I_p = \text{primary setting current}$

The equation for the overcurrent relay based on the IEC standard for normal inverse work can be written as:

$$t_{relay} = \frac{0,14 \times TMS}{\left(\frac{I_F}{CTR \times PS}\right)^{0,02} - 1} \quad (20)$$

Where: TMS = Time multiplier Setting  
 CTR = Current transformer ratio  
 PS = Plug setting  
 I<sub>F</sub> = Fault primary current

TMS was analyzed by the equation:

$$TMS = \frac{(0,3) \times \left(\frac{I_F}{CTR \times PS}\right)^{0,02} - 1}{0,14} \quad (21)$$

## IV. Discussion

### a. System Data

Online diagram of an 8 bus system with 3 generator units interconnected with the transmission line, as shown in figure 6.

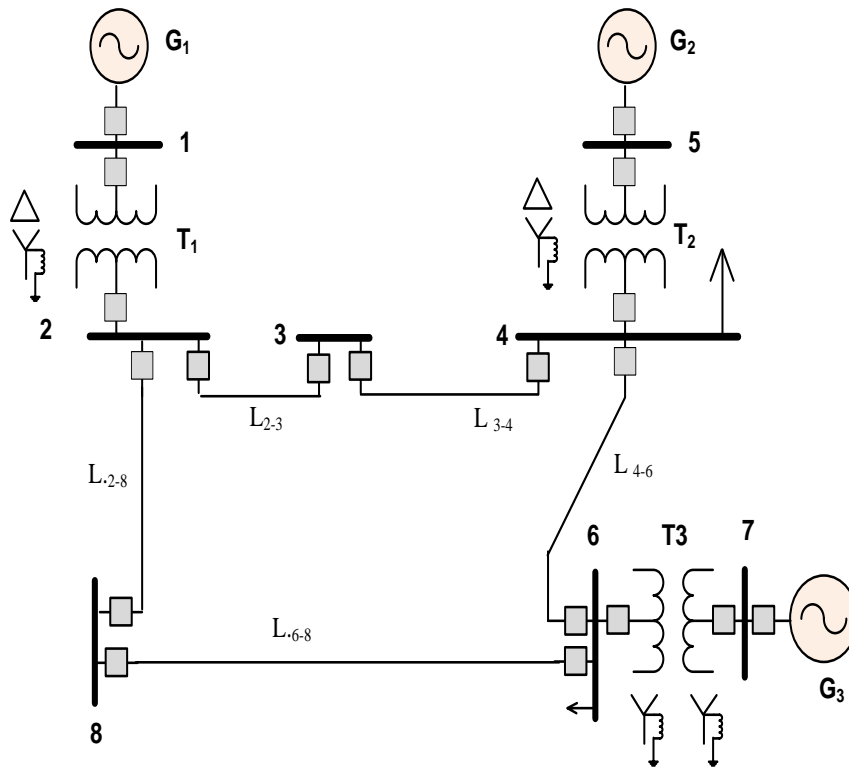

*Figure 6. System for Short Circuit Analysis Example*

Figure 6 shows a circuit diagram of the electric power system, consisting of 8 buses, 3 generating units each on buses 1, 5 and 7. Bus 1 is connected to the power transformer with the primary side connected to the delta, while the secondary side is connected to the grounded star. Through a shunt reactor with a grounding impedance of 0.03 pu. similar to T2 on bus 5, while on bus 7 there is a star-connected power transformer with a grounding impedance of 0.03 pu. The entire generator is also grounded by a shunt reactor with a grounding impedance of 0.03 pu. for other data, given in table 1.

**Table 1.** 5 bus system data

ITEM	MVA RATING	VOLTAGE RATING	X <sub>1</sub>	X <sub>2</sub>	X <sub>0</sub>
G <sub>1</sub>	100	25 kV	0.22	0.22	0.05
G <sub>2</sub>	100	13.8 kV	0.20	0.20	0.05
G <sub>3</sub>	100	13.8 kV	0.20	0.20	0.05
T <sub>1</sub>	100	25/150 kV	0.05	0.05	0.05
T <sub>2</sub>	100	13.8/150 kV	0.05	0.05	0.05
T <sub>3</sub>	100	150 kV	0.05	0.05	0.05
L <sub>2-3</sub>	100	150 kV	0.14	0.14	0.35
L <sub>3-4</sub>	100	150 kV	0.17	0.17	0.32
L <sub>4-5</sub>	100	150 kV	0.18	0.18	0.35
L <sub>4-6</sub>	100	150 kV	0.15	0.15	0.34
L <sub>2-8</sub>	100	150 kV	0.25	0.25	0.41
L <sub>6-8</sub>	100	150 kV	0.22	0.22	0.39

In determining the setting time and current values for the GFR relay, the following analysis steps are carried out:

*MVA Base (pu):* 100 MVA

$$25 \text{ kV} \quad I = \frac{100}{0.025\sqrt{3}} = 2310 \text{ A}$$

$$230 \text{ kV} \quad I = \frac{100}{0.23\sqrt{3}} = 251 \text{ A}$$

$$13.8 \text{ kV} \quad I = \frac{100}{0.0138\sqrt{3}} = 4184 \text{ A}$$

Determine the value of short circuit impedance with the Zbus matrix method. The impedance value is obtained from the reactance diagram based on Figure 5. The next bus admittance values are inverted to obtain the Zbus matrix for both positive and negative sequences, as given in the following matrix results:

$$Z_{rel} = [Y_{rel}]^{-1}$$

$$Z_{bus1} = Z_{bus2} = \begin{vmatrix} 0.1370i & 0.1181i & 0.0869i & 0.0491i & 0.0393i & 0.0468i & 0.0362i & 0.0793i \\ 0.1181i & 0.1449i & 0.1067i & 0.0603i & 0.0482i & 0.0555i & 0.0444i & 0.0974i \\ 0.0869i & 0.1067i & 0.1749i & 0.0877i & 0.0702i & 0.0635i & 0.0508i & 0.0837i \\ 0.0491i & 0.0603i & 0.0877i & 0.1211i & 0.0969i & 0.0731i & 0.0585i & 0.0671i \\ 0.0393i & 0.0482i & 0.0702i & 0.0969i & 0.1175i & 0.0585i & 0.0468i & 0.0537i \\ 0.0468i & 0.0555i & 0.0635i & 0.0731i & 0.0585i & 0.1255i & 0.1004i & 0.0927i \\ 0.0362i & 0.0444i & 0.0508i & 0.0585i & 0.0468i & 0.1004i & 0.1203i & 0.0742i \\ 0.0793 & 0.0974i & 0.0837i & 0.0671i & 0.0537i & 0.0927i & 0.0742i & 0.2119i \end{vmatrix}$$

$$Z_{bus0} = \begin{vmatrix} 0.1400i & 0.0000i & 0.0000i & 0.0000i & 0.0000i & 0.0000i & 0.0000i & 0.0000i \\ 0.0000i & 0.5949i & 0.4221i & 0.2641i & 0.0000i & 0.1900i & 0.1400i & 0.3874i \\ 0.0000i & 0.4221i & 0.5236i & 0.2965i & 0.0000i & 0.1900i & 0.1400i & 0.3031i \\ 0.0000i & 0.2641i & 0.2965i & 0.3261i & 0.0000i & 0.1900i & 0.1400i & 0.2261i \\ 0.0000i & 0.0000 & 0.0000i & 0.0000i & 0.1400i & 0.0000i & 0.0000i & 0.0000i \\ 0.0000i & 0.1900 & 0.1900i & 0.1900i & 0.0000i & 0.1900i & 0.1400i & 0.1900i \\ 0.0000i & 0.1400i & 0.1400i & 0.1400i & 0.0000i & 0.1400i & 0.1400i & 0.1400i \\ 0.0000i & 0.3874i & 0.3031i & 0.2261i & 0.0000i & 0.1900i & 0.1400i & 0.4861i \end{vmatrix}$$

The fault current value of each bus is obtained through the ground fault current equation, based on the results of the positive sequence Zbus matrix, negative sequence and zero sequence, the fault current value is obtained, assuming the ground fault impedance  $Z_f = 0.1$  pu. with equation (14), the magnitude of the fault current of each bus in pu is obtained. The calculation of single-phase short-circuit to ground, based on bus impedance matrix data, is carried out using Matlab software as an analytical tool. From the results of the simulation calculations, the data obtained from the analysis results are shown in table 2.

**Table 2.** The Simulation Results of the Assumed Ground Fault Current  $I_f$  It Occurs on Each Bus

Short Circuit Location	Single phase ground fault (PU)	Base Current (Ampere)	Single Phase Ground Fault (Ampere)
1	5.8685	4.184	24.539,16
2	3.1529	4.184	13.191,73
3	3.1882	4.184	9.155,43
4	4.4952	4.184	18.807,92
5	6.2473	4.184	26.138,70
6	5.3287	4.184	22.295,28
7	6.1902	4.184	25.899,80
8	3.0771	4.184	12.874,59

The condition of the feeder on bus 1 as a basis, is used to determine the GFR rating to trip the CB circuit. For setting the GFR in this case, it is taken from the smallest 1 Phase to ground short circuit fault current based on the simulation of the fault point location. The location of the fault point will produce an equivalent short-circuit impedance value, from the simulation results of the fault analysis, it can be seen that the positive, net, and zero equivalent impedance values are the largest if there is a fault on bus 8, so that the smallest fault current exists if the system experiences a single-phase fault. Ground on bus-8, the table shows the results of 3,071 pu. It can be seen that the equivalent reactance in the highest Zbus matrix on bus 8 is caused by a single-phase conductor in contact with the ground which causes high resistance, which will cause a small short-circuit fault current in the system.

#### **b. GFR Setting Setting Analysis Simulation**

The primary current used for GFR setting is taken from fault current single phase short circuit to ground smallest, in table 2 obtained 3,071 pu, so : Determination of the PS value of the overcurrent relay, can be done by analyzing for example the current is 5A, 2.2 seconds which has a plug setting  $P_s = 200\%$ . The CT supply ratio is 400:5A and under fault current conditions is 12000Amp. Than  $I_p = 4184$  A and  $I_s = 4184 \times (5/400) = 52,3$ A; on PS of 200%: The relay current:  $5 \times (200/100) = 10$ A; Hence Plug setting  $PS = 52,3/10 = 5,2$

The  $t_{\text{relay}}$  equation (equation 20) is an analysis to determine the breaker time when the system experiences a single-phase ground fault, figure x, shows the simulation analysis of the TMS and Tsett relay calculations, from the simulation it is obtained that the TMS is 0.8275 while the relay is 2,45 seconds.

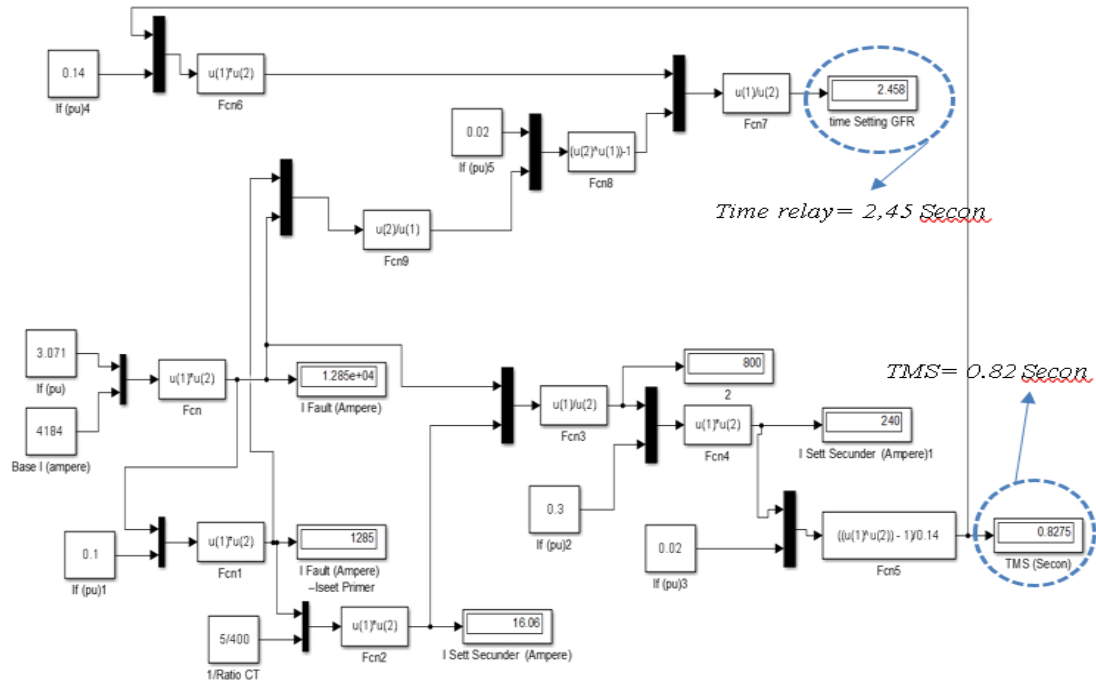

Figure 7. TMS and t Relay Values Using Simulation Analysis

Figure 7. shows the simulation results of TMS and t relay values using matlab simulink analysis. The TMS equation is used in determining the length of time the CB opens when the system experiences a single-phase short circuit to ground, the value of the GFR relay setting can be set in the order of 2.45 seconds, based on the calculation results.

### c. Validation by Expert: TMS and t Relay Values Using Simulation Analysis

Validation was carried out by experts, to see the truth of the simulation analysis of determining TMS and setting time by experts, on the simulation calculations from Figure 6. The assessed aspects consisted of 7 categories, namely (1). Simulation ease (2) Data analysis (3) System modeling (4) Relationship between paramteric in simulation (5) Ease of reading data and ease of data input. of these seven aspects, the average expert assessment is in the position of 0.872 in the good category. This means that the data analysis and analysis method using matlab simulation are valid for use in protection learning to determine the value of the GFR relay setting. This simulation model will be applied in the learning process, because the strategy model can improve the quality of student learning effectively compared to conventional methods (Emilda, 2021). The validation calculation plot by the expert is shown in Figure 8.

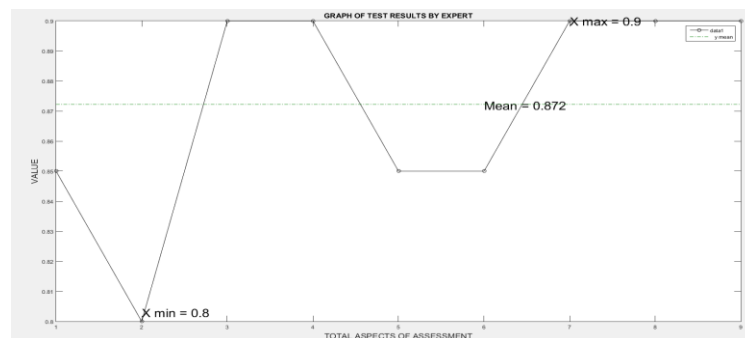

Figure 8. Plot of GFR Calculation Simulation Validation Calculations by Experts

## V. Conclusion

From the results of the analysis of the determination of the value of the GFR setting based on a single-phase fault current to ground, it can be concluded

1. The results of the analysis of a single-phase short-circuit fault analysis to ground, using a calculation simulation model, the magnitude of the fault current is 3.07 times greater than the nominal current, if it is not removed in a short time, it will have an impact on equipment damage.
2. The magnitude of the single-phase ground fault current is used as a parameter to find the TMS value and Time Setting on the GFR, obtained TMS of 0.82 seconds and time setting of 2.45 seconds, can be used to secure equipment from short-circuit current flowing of 3.07 times greater than the nominal current. The magnitude of 3.07 pu is the minimum short-circuit fault current value, based on the simulation.
3. GFR calculation simulations for learning the protection system can be used based on the results of expert validation in the good category. Expert assessment of 7 aspects of the simulation media used is declared valid.

## References

- ABB- Technical Guide - 6th Edition 2010," Electrical Installation Handbook Protection, Control and Electrical Devices Sixth Edition 2010 Published by ABB SACE via Baioni, 35 - 24123 Bergamo (Italy).
- Alstom G., (2011), "Network Protection & Automation Guide, Edition May 2011, May 2011 ISBN: 978-0-9568678-0-3
- Asnal Effendi, (2013)," Analisis Hubungan Singkat Satu Phasa Ke Tanah Terhadap Pengaturan Setting GFR Pada Feeder 20 Kv (Application GI Pauh Limo)", Jurnal Reka Elkomika ©Teknik Elektro, Itenas, Vol., No.1 2337-439X Januari 2013 Jurnal Online Institut Teknologi Nasional.
- Emilda Sulasmi?, (2021) Effectiveness of Modeling Learning Strategies to improve Student Learning Outcomes", DOI: <https://doi.org/10.33258/birci.v4i1.1694> Budapest International Research and Critics Institute-Journal (BIRCI-Journal) Volume 4, No 1, February 2021, Page: 926-936 e-ISSN: 2615-3076 (Online), p-ISSN: 2615-1715
- Hadi Saadat (1999)," Power System Analysis", Volume 1. WCB/McGraw-Hill.
- Junaidi. A., Abdul Hamid K. (2017) Design of Simulation Product for Stability of Electric Power System Using Power System Stabilizer and Optimal Control. IOP Conf. Series: Journal of Physics: Conf. Series 970, 1-7.
- Maharani Putri & Rahmaniar, (2017). The Simulation Computer Based Learning (SCBL) for Short Circuit Multi Machine Power System Analysis. IOP Conf. Series: Journal of Physics: Conf. Series 970.
- Metz B. de, Noblat, F. Dumas, C. Poulain, (2005)," Cahier technique no. 158, Calculation of short-circuit Currents", <http://www.schneider-electric.com>
- Nasser D. Tleis (2008)," Power Systems Modelling and Fault Analysis", Theory and Practice Published by Elsevier Ltd. All rights reserved ISBN-13: 978-0-7506-8074-5
- Rahmaniar, agus Junaidi, et al (2019). Modelling And Simulation: An Injection Model Approach to Controlling Dynamic Stability Based on Unified Power Flow Controller. Journal of Theoretical and Applied Information Technology, ISSN: 1992-8645, Vol.97. No 20, 2334-2345.